

OKAYO

UHF-PLL 16-96 Channel

Diversity Wireless Microphone System



EJ-701DR Single-channel Diversity Receiver

EJ-702DR Dual-channel Diversity Receiver

EJ-703DR Dual-channel Diversity Receiver

EJ-704DR Quad-channel Diversity Receiver

[User Manual]

Preface

Thank you for purchasing EJ-701DR/EJ-702DR/EJ-703DR/EJ-704DR Diversity Wireless Microphone Systems. This manual includes complete instructions of operation and function. Please read before you start using.

INDEX

EJ-701DR Single-channel Diversity Receiver Illustrations.....	1
EJ-702DR Dual-channel Diversity Receiver Illustrations.....	2
EJ-703DR Dual-channel Diversity Receiver Illustrations.....	3
EJ-704DR Quad-channel Diversity Receiver Illustrations.....	4
EJ-701~704DR Setup Procedure.....	5~6
Wireless receiver Module Illustrations.....	7
Wireless handheld Mic Illustrations.....	8~9
Wireless bodypack transmitter Illustrations.....	10~11
Important Notes.....	11
Frequencies Combination.....	12
Important Points when Using Different Channels.....	13
Specifications.....	14~15
MEMO.....	16

EJ-701DR Single-channel Diversity Receiver Illustrations

A

A EJ-701DR Single-channel Diversity Receiver

1/2U Size

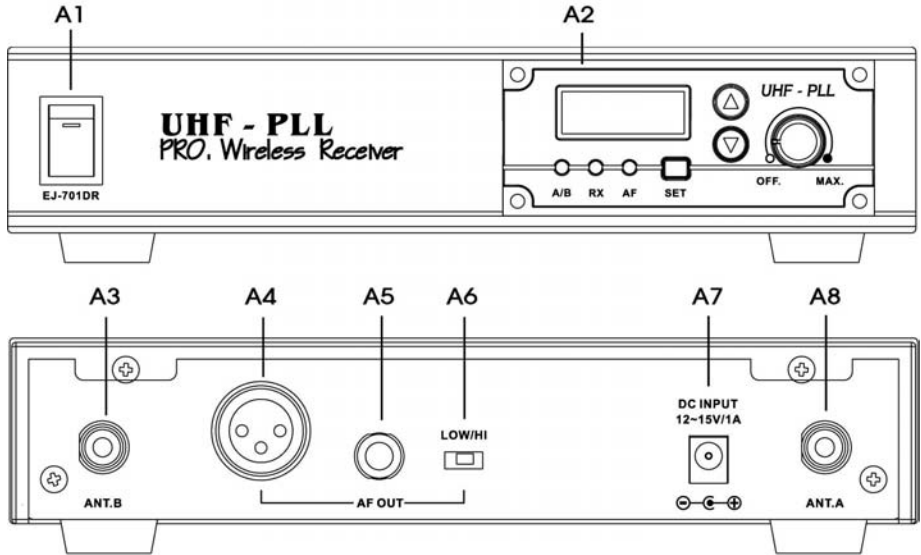

- A1.** Power Switch
- A2.** Receiver Module
- A3.** Antenna B
- A4.** Balanced AF XLR Output
- A5.** Unbalanced AF Output (6.3 mm jack)
- A6.** AF Impedance Selection (for A5)
- A7.** DC Power Socket
- A8.** Antenna A

B EJ-702DR Dual-channel Diversity Receiver

1/2U Size

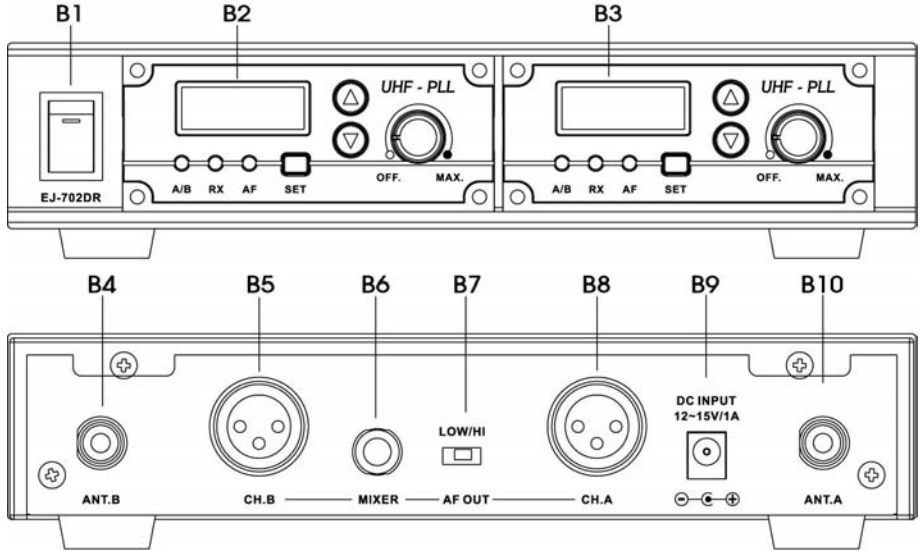

- B1.** Power Switch
- B2.** Receiver Module A
- B3.** Receiver Module B
- B4.** Antenna B
- B5.** Balance AF Output (XLR)
- B6.** Unbalanced AF Output (6.3 mm)
- B7.** AF Impedance Selection (for B6)
- B8.** Balanced AF Output
- B9.** DC Power Socket
- B10.** Antenna A

C EJ-703DR Dual-channel Diversity Receiver

1U Size

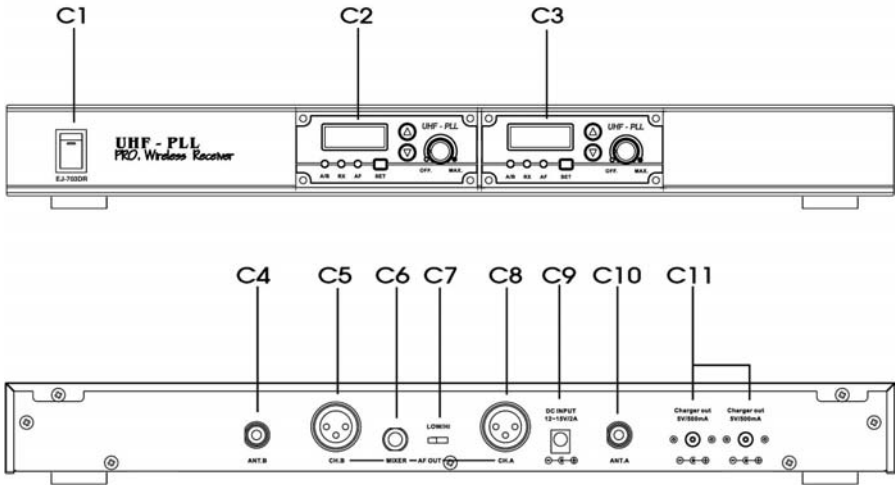

- C1.** Power Switch
- C2.** Receiver Module A
- C3.** Receiver Module B
- C4.** Antenna B
- C5.** Balance AF Output (XLR)
- C6.** Unbalanced AF Output
- C7.** AF Impedance Selection (for C6).
- C8.** Balanced AF Output (XLR)
- C9.** DC Power Socket
- C10.** Antenna A
- C11.** Charging Socket for Mic: EJ-701TS/TM

※Charging method please refer to the page 9 "Wireless Handheld Mic Illustrations".

D EJ-704DR Quad-channel Diversity Receiver

1U Size

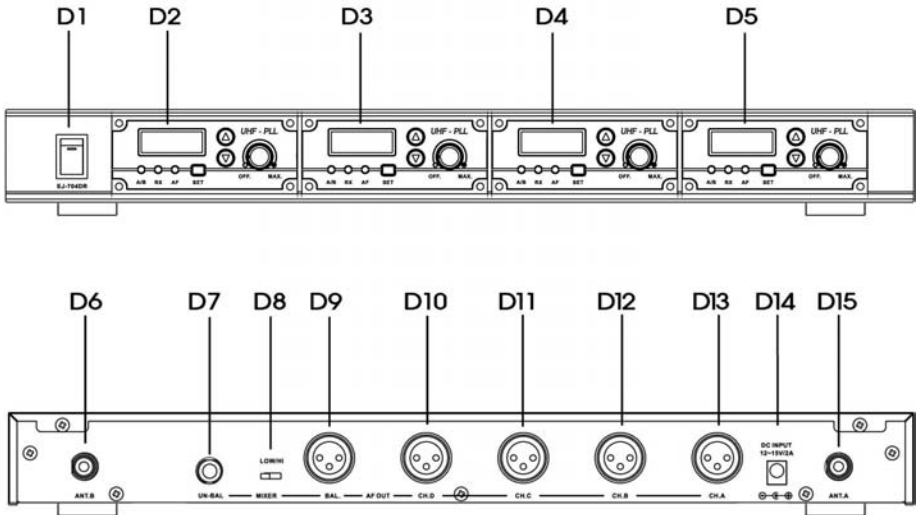

- D1.** Power Switch
- D2.** Receiver Module A
- D3.** Receiver Module B
- D4.** Receiver Module C
- D5.** Receiver Module D
- D6.** Antenna B
- D7.** Unbalanced AF Output (6.3 mm)
- D8.** AF Impedance Selection (for D7, D9)
- D9.** Balanced AF Output (XLR)
- D10.** Balanced AF Output (XLR)-Receiver D
- D11.** Balanced AF Output (XLR)-Receiver C
- D12.** Balanced AF Output (XLR)-Receiver B
- D13.** Balanced AF Output (XLR)-Receiver A
- D14.** DC Power Socket
- D15.** Antenna A

EJ-701~704DR Setup Procedure



Setting up antenna on the receiver.

Please set up the enclosed 2 antennas on the rear panel (Antenna A, B) and then adjust the antenna's angle.

Signal Connections

1. Connect 6.3 mm mic jack from "unbalanced AF Output" to amplifier's "Mic In". (The same way can be applied in EJ-701/702/703/ 704DR.)

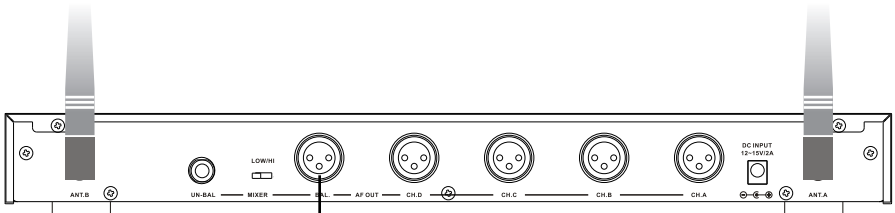
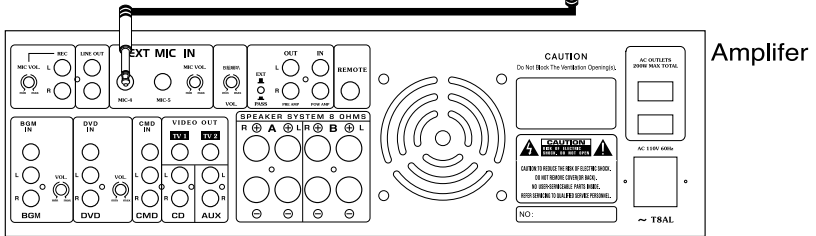
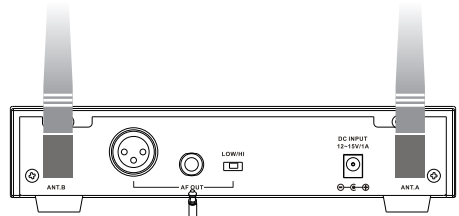

2. If using XLR mic jack, connect it from "Balanced AF Output" to amplifier's "Mic In".

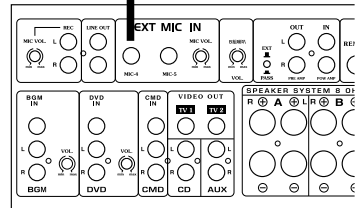

In order to avoid the impedance might be too high thus producing noise, please set "impedance" at "Low" when you are connecting a mic jack to a "low input" in the subordinate device. If your subordinate device is with general input socket (ex., LINE IN, AUX IN...etc), please set "impedance" at "High" to avoid too low volume output.

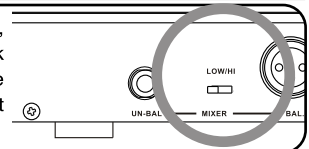

EJ-701~704DR Setup Procedure

Signal Connections

3. When using with a mixer, connect XLR mic jack from "Balanced AF Output" to mixer's "MIC IN" (adjust "Impedance" at Low); or to mixer's "LINE IN" (adjust "Impedance" at Hi). This way can be applied on EJ-701/702/703/704DR.

Note:

EJ-704DR has an XLR mixer balanced AF output (#D9), others don't. In EJ-701~703DR the HI/LOW "#F Impedance Selection" can only adjust the 6.3 mm jack "unbalanced AF Output" However in EJ-704DR HI/LOW the "AF Impedance Selection" can adjust not only "Unbalanced AF Output (6.3 mm, #D7)" but also its XLR mixer "Balanced AF Output (D9)."

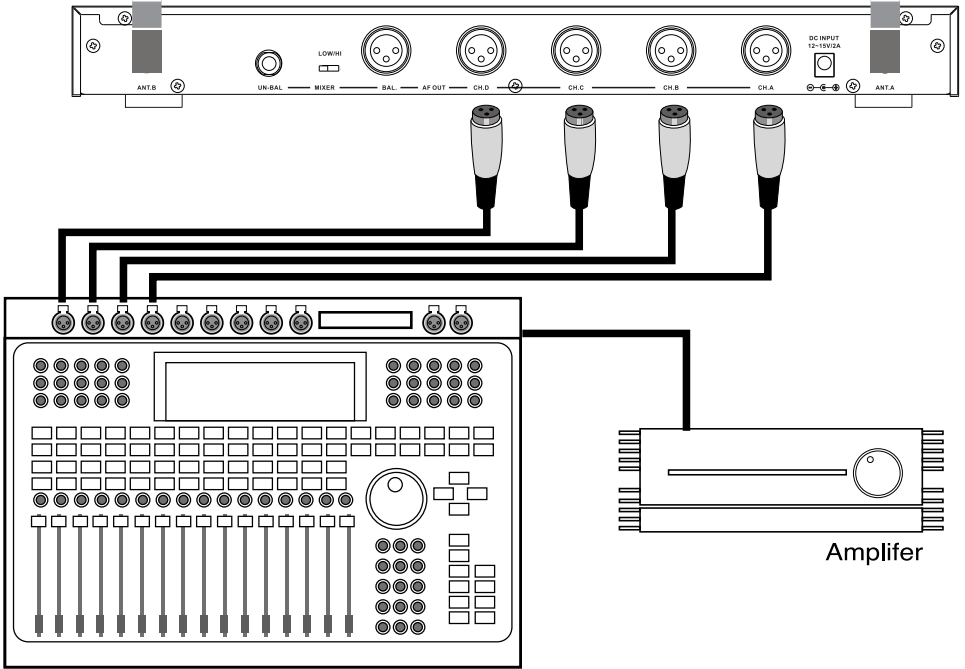
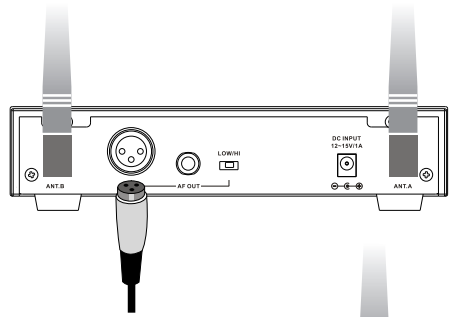

Power source supply

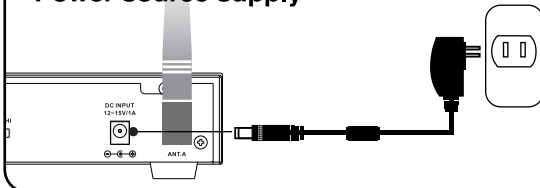

Please use our product's AC Switching Adaptor.

- EJ-701DR/702DR (100-240 VAC/12 VDC, 1 A)
- EJ-703DR/704DR (100-240 VAC/12 VDC, 2 A)

E UHF Receiver Module Operating

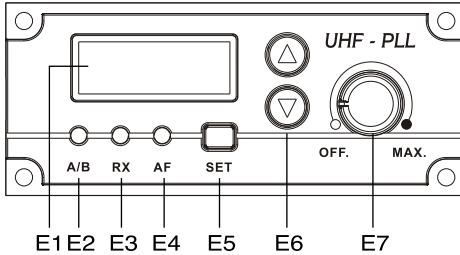

- E1. LCD Screen
- E2. Antenna A/B indicator
- E3. RF Signal Indicator
- E4. AF Audio Signal Indicator
- E5. Frequency Set Button
- E6. Up/down Frequency Selector
- E7. Knob (Receiver Module Power Switch/ Volume Control)

UHF Receiver Module Operating Way

1. Turn "Knob (E7)" clockwise and you will hear a click, then LCD screen will be on and show a channel number, it means you successfully turn on the receiver module. Continue to turn the knob to adjust its volume.



(Vice versa, turn Knob counter-clockwise till you hear a click, then LCD will show the words "OFF" for about 2~3 seconds. LCD will be off after this procedure.)

2. Set, Select the Channels:

After receiver module is on, LCD will show channel number, for example, to select a channel, hold on "SET (E5)" for one second then the number starts to blink. Press "Up/down Frequency Selector" to look for your preferred channel number (1~96). Press "SET" again to finish channel setting.

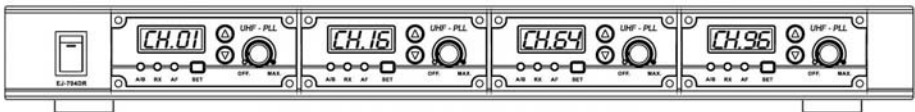
※ Use the same setting way for EJ-702/703/704DR. Each receiver module has to be at different channel.



3. Press   to show the frequency being used.

F Handheld UHF Wireless Microphone (EJ-701TS / 701TM)

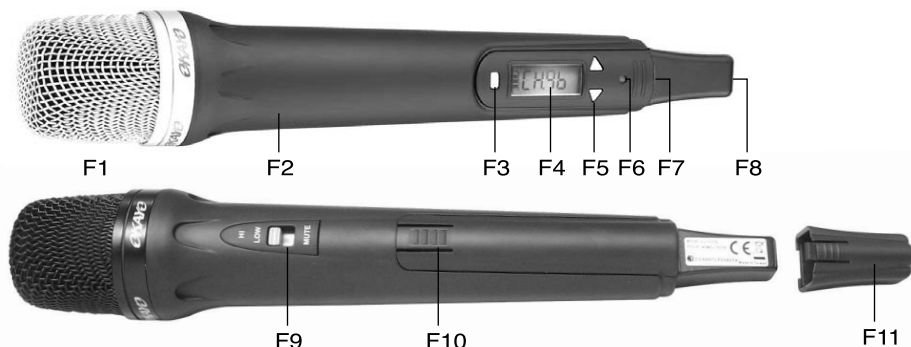

- | | | |
|--|---------------------------------------|---------------------------|
| F2. Rubberized body | F5. Up/down frequency selector | F9. HI/LOW/MUTE |
| F3. Frequency set button | F6. LED power indicator | F10. Battery Cover |
| F4. LCD screen
(indicating Channel /
Frquency / Battery life) | F7. Power switch | F11. Button Cap |
| | F8. Charging port connection | |

F Put Batteries in Microphones (EJ-701TS/701TM)



1. Take off Button Cap (F11)
 2. Pull down Battery Cover.
 3. Put in 2 batteries in right direction.
(2 pcs **AA 1.2 V** Ni-MH 1600 mAh rechargeable batteries or 2 pcs **1.5 V AA** disposable battery)
- ※ **Put the Button Cap back. (F11) This movement can insure the battery cover is locked to avoid that batteries fall off**



Notice! Do not use capacity battery
(Ex: over 2300mAh, batteries might stock in the battery case and can't be taken out)

F Wireless Microphone (EJ-701TS Operation / Channel Setup)

1. Hold on the Power button beside the button cap for (2 ~ 3 seconds), LED power indicator will be on and show On
2. **Set and select a channel:**
Turn on EJ-701TS/TM, LCD will show the channel number, for example CH.01 .
To select a channel, hold on "SET (F3)" for 2~3 seconds then the number starts to blink CH.01 . Press "Up/down Frequency Selector (F5)" to look for your preferred channel number (1~96). Press "SET (F3)" again to finish channel setting.
- ※ Please set the channel the same as receiver module.
- ※ Use the same setting way when applying **EJ-702/703/704**. Transmitter and receiver must have equivalent channel to work together.
3. Press △ ▽ to show the frequency being used.



F Wireless Microphone (EJ-701TS/EJ-701TM)

(F9) HI-Very sensitive LOW-Less sensitive MUTE-Silence

When you are not using the microphone temporarily, you can switch to "MUTE" in silent mode. Switch back to "HI/LOW" and then you can start to use the microphone again.



You can find the power status from the  on LCD screen. If the power is going to be out of use, the microphone may not work as usual. Please use 1.2 V. Ni-MH1300 or 1600 mAh rechargeable batteries or 1.5 V Alkaline disposable batteries.

To Recharge the Wireless Microphone (EJ-701TS / EJ-701TM)



(Optional accessory 1.)

When the power of rechargeable batteries is insufficient, you can recharge the batteries by connecting the microphone and charger via the recharging cable.

1. Put the two sides of cable in F10 of the microphone and C11 at the back of 703DR to recharge the microphone.

(Please find the correct location indicators on page 3rd)

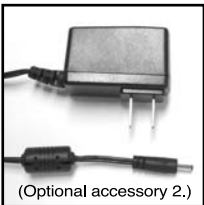

(Optional accessory 2.)

※ *Only receiver module EJ-703DR provides this function.*

2. Please ask your local supplier for the specific travelling charger.



Notice!!

※ Alkaline disposable batteries can not be recharged. Recharging alkaline disposable batteries can cause a great danger such as leakage or explosion.

G Bodypack UHF Wireless Transmitter (EJ-7LT / EJ-7XT)

- G1. Antenna
- G2. Mute Control
- G3. Power Switch
- G4. 3.5 mm (EJ-7LT) or 3-pin (EJ-7XT) Microphone Input
- G5. LED Power Indicator
- G6. Sensitivity Selection
- G7. AUX In
- G8. Frequency Set
- G9. Built-in Microphone
- G10. Turn Up/Down Frequencies
- G11. LCD Screen
- G12. Recharge Jack

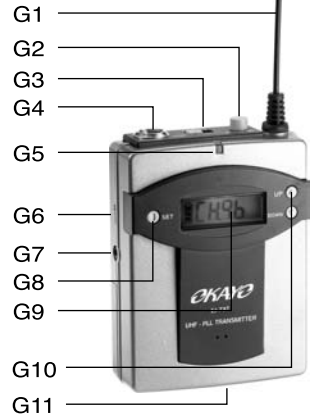

G (EJ-7LT/ 7XT) To install the batteries

1. Push the battery cover gently and then pull it out.
2. Place 2 pieces 1.2 V rechargeable batteries (Ni-MH.1600 mAh) or 2 pieces 1.5 V Alkaline disposable batteries in the case according to the ⊕ and ⊖ direction, and then place the battery cover back.



G (EJ-7T/ 7LT/ 7XT) User Instruction

1. Turn on the Power Switch (G3). The LED indicator becomes red and the LCD screen is on.
2. **To set the channel:**
 After turning on the unit, the current channel CH.01 is shown on the LCD. Press "SET" (G8) for 2-5 seconds until the channel number starts to blink CH.01, and then press Up or Down (G10) to select the channel from 1-96. Press "SET" (G8) again after setting the channel.
 - ※ **The transmitter and receiver should set be on the same channel.**
 - ※ **Set the channels for EJ-702/ 703/ 704DR as same as the above instruction.**
3. EJ-7LT is recommended to use with LM-90S lapel microphone or HM-50S headset microphone.
 EJ-7XT is recommended to use with LM-90C lapel microphone or XLT mini headset microphone.

Wireless Bodypack Transmitter Illustrations

G



You can adjust the sensitivity microphone for different purposes. (G6)

HI-very sensitive MID-the average LOW-less sensitive

AUX IN-to connect with external sound source, such as MP3....(G7)

MUTE-When you are not using the microphone temporarily, you can press "MUTE" in silent mode (G2). Press again and then you can start to use the microphone.



You can find the power status from  on LCD. If the power is going to be out of use, the module may not work as usual. Please use 1.2 V Ni-MH.1600 mAh rechargeable batteries with the charger HDC-707 or 1.5 V Alkaline disposable batteries.

Notice!!

※ Alkaline disposable batteries can not be recharged. Recharging alkaline disposable batteries can cause a great danger such as leakage or explosion.



HDC-707

Notes

1. The antenna must be fixed firmly
2. The distance between the transmitter and receiver should be more than 1 metre.
3. Avoid dankness and shower.
4. Avoid clash, falling or throwing down.
5. Use the recommended charger only in order to avoid damage and danger.

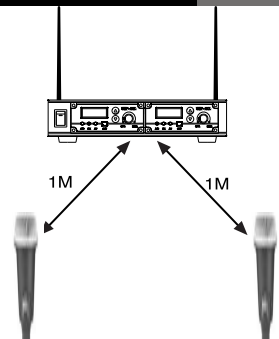

Frequency Combination

Frequency: 640 MHz

1. Use 4 channels at the same time.

(1) 19 20 35 36 (2) 10 57 58 59 (3) 19 34 36 39 (4) 20 35 39 69
(5) 59 75 77 90 (6) 11 44 45 57 (7) 07 53 84 87

2. Use 8 channels at the same time.

(1) 06 39 42 45 55 70 89 90 (2) 17 18 20 33 34 36 37 89
(3) 01 02 06 37 49 50 70 84 (4) 02 49 50 52 68 69 71 86
(5) 34 40 52 57 68 69 81 82

2. Use 12 channels at the same time.

(1) 20 21 49 50 58 65 66 71 75 84 85 87
(2) 02 17 21 22 25 26 41 42 67 82 85 86

Frequency: 740 ~ 752 MHz

1. Use 4 channels at the same time.

(1) 01 29 52 96 (2) 20 48 49 61 (3) 03 04 32 63 (4) 17 21 28 80
(5) 36 55 64 65 (6) 16 33 69 90 (7) 08 59 81 94 (8) 03 1146 56

2. Use 8 channels at the same time.

(1) 01 02 19 39 45 53 64 70 (2) 01 02 19 32 39 45 53 70 (3) 17 30 44 52 58 59 95 96
(4) 30 33 44 52 58 59 95 96 (5) 17 27 30 44 52 58 95 96 (6) 27 30 33 44 52 58 95 96
(7) 01 02 11 19 46 62 86 96

Frequency: 794 ~ 806 MHz

1. Use 4 channels at the same time.

(1) 04 06 08 10 (2) 12 14 16 22 (3) 28 32 52 56 (4) 34 36 38 40
(5) 42 44 46 55 (6) 60 64 82 86 (7) 58 68 76 78 (8) 17 19 21 23
(9) 25 27 29 31 (10) 88 84 92 94 (11) 49 51 53 55 (12) 57 59 61 63

2. Use 8 channels at the same time.

(1) 01 02 19 39 45 53 64 70 (2) 01 02 19 32 39 45 53 70
(3) 17 30 44 52 58 59 95 96 (4) 30 33 44 52 58 59 95 96
(5) 17 27 30 44 52 58 95 96 (6) 27 30 33 44 52 58 95 96 (7) 01 02 11 19 46 62 86 96

3. Use 12 channels at the same time.

(1) 01 17 19 27 30 42 57 58 73 83 91 92 (2) 01 03 07 21 24 30 32 36 73 86 92 96
(3) 01 02 07 30 54 64 66 68 73 83 90 93

Frequency: 863 ~ 865 MHz

1. Use 4 channels at the same time.

(1) 03 04 05 06 (2) 01 02 14 16 (3) 01 02 12 13 (4) 02 03 05 08
(5) 03 08 14 15 (6) 04 09 15 16 (7) 05 12 14 15 (8) 06 13 15 16
(9) 07 12 13 14 (10) 08 09 14 15 (11) 09 12 14 15 (12) 10 13 15 16

2. This frequency band can not support more than 4 channels at the same time.

Important Points when Using Different Channels

1. When using different channels, the distance between each transmitter should be over 30 cm; the overall range of transmitters should be under 40 m.
2. The transmitter should be switched to "MUTE" in silent mode when it is not engaged in order to avoid interference.
3. EJ-701DR/702DR/703DR/704DR need to be turned off when you are changing the batteries for the transmitter. After changing the batteries, the transmitter should be turned on before than EJ-701DR/702DR/703DR/704DR.

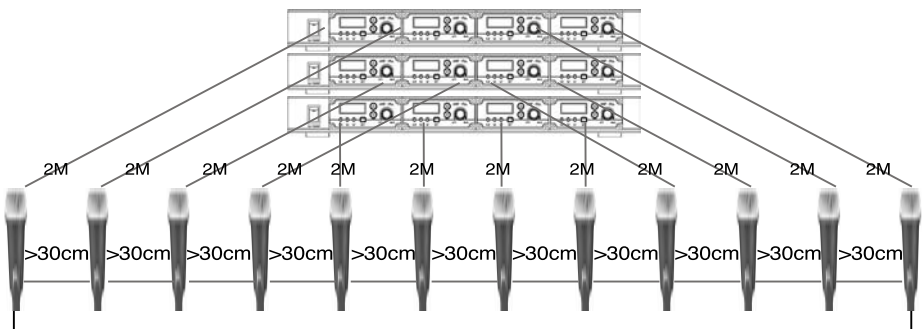
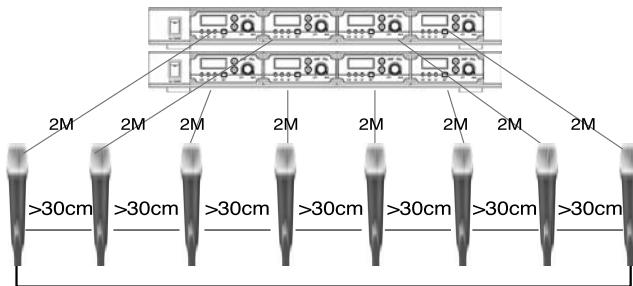
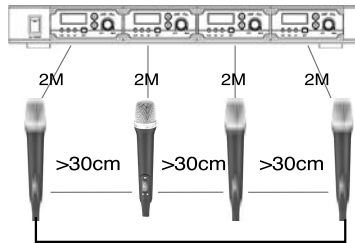

Specification

Key Specification / Overall System

Carrier frequency range	① 640 MHz (96channels) ② 740 ~752 MHz (96 channels)
(channels)	③ 794 ~ 806 MHz (96channels) ④ 863 ~ 865 MHz (16 channels)
LCD indication	channel, frequency, and battery status
Frequency selector	SET, UP, DOWN
Switching Bandwidth	Max. 12 MHz
Ambient response	-10°C ~ 50 °C
Maximum deviation	80 kHz, with level limiting
Dynamic range	110 dB
T. H. D	Less than 0.5 %
Pre/ De-emphasis	50 μ s
Silent mode	Squelch Tone key and noise lock dual-squelch
Frequency response	70 Hz~17 kHz
Available distance	Operating range 70 ~100 Meter (open field)
Patent and certification	new and exclusive design is confirmed by CD. FCC. NCC declaration

EJ - 701DR / EJ - 702DR

Receive module	DR-701 X 1 (EJ-701DR), DR-701 X 2 (EJ-702R)
Antenna	TNC connector swivel antenna
Audio output	6.3 \varnothing Mic-out (mixer), XLR-balanced
Output level	CH-out: 80 mV Mixer out: Low 80 mV Hi 700 mV
Power supply	100 ~ 240 VAC/12 VDC, 1 A switching power supply
Size	D 210 x W 215 x H 44 (mm)
Weight	1.2/1.4 kg

EJ - 703DR / EJ - 704DR

Receive module	DR-701 X 2 (EJ-703DR), DR-701 X 2 (EJ-704DR)
Antenna	TNC connector swivel antenna
Audio output	XLR-Combo Mic-out (mixer), XLR-balanced
Output level	CH-out: 80 mV Mixer out: Low 80 mV Hi: 700 mV
Power supply	100 ~ 240 VAC/12 VDC, 2 A switching power supply
DC output:	5V/500 mA x 2 (EJ-701TS can be charged by EJ-703DR)
Size	D 210 x W 430 x H 44 (mm)
Weight	2.2/2.4 kg

Specification

EJ-7LT/EJ-7XT Bodypack Receiver

Capsule	condenser microphone
Antenna	flexible antenna
RF output	10 mW
Spurious emission	less than 250 nW
Audio input	Mic in, Aux in
Input jack	screw-type (EJ-7LT), mini XLR (EJ-7XT)
AF controls	Mute switch, Hi/Mid/Low switch
Battery	1.2 V (Ni-MH.1600 mAh) x 2 AA type rechargeable battery 1.5 V x 2 AA Alkaline disposable batteries
Power supply	11 hours typical in Ni-MH. rechargeable batteries 14 hours typical in Alkaline disposable
Housing	aluminium
Size	D 26 x W 64 x H 88 mm
Weight	170 g with batteries

EJ-7TS/EJ-7TM Handheld Wireless Microphone

Capsule	dynamic capsule (EJ-701TS) or cardioid condenser capsule (EJ-701TM)
Antenna	built-in
RF output	10 mW
Spurious emission	less than 250 nW
AF controls	Hi/Low/Mute switch
Battery	1.2 V (Ni-MH.1600 mAh) x 2 AA type rechargeable battery 1.5 V x 2 AA Alkaline disposable
Power supply	11 hours typical in Ni-MH. rechargeable batteries 14 hours typical in Alkaline disposable batteries
Size	46 x 264 mm
Weight	280 g

OKAYO

Sound & Communication

E-J ELECTRONICS CO., LTD.

4F, No.11, Lane 125, Sec 1, Kuo Kwang Rd., Ta Li City,
Taichung Hsien, Taiwan

Tel:886-4-2407-1617 Fax:886-4-2407-1609

e-mail:okayo@okayo.com
www.okayo.com